



SV5108, SV5108A

**Low Power, 5th-order 8MHz filter, Quality Enhanced,
Standard Definition Video Driver**

Revision v1.3a
SAVITECH Corporation

SV5108, SV5108A

Low Power, 5th-order 8MHz filter, Quality Enhanced, Standard Definition Video Driver

Features

- Low power, low voltage design
- Operating voltage from +2.7V to +5.5V
- Low quiescent current: 6mA
- High PSRR: 62dB
- No compromised HBM 8KV ESD protection
- 5th-order filter integrated : 8MHz
- High-performance, +6dB-gain driver design
- Support Power-Down mode/Jack-Detect enabled (SV5108A)
- Rail-to-Rail output
- Transparent input clamping
- Versatile AC- or DC-coupled configurations at inputs and outputs
- PCB space saving design in green SC70-5, SC70-6 and SOP-8

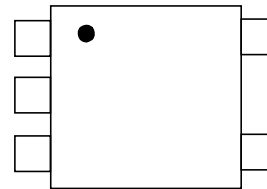

SC70-5

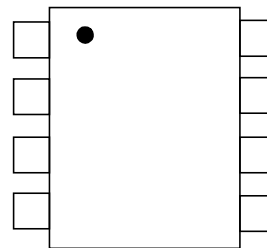

SOP-8

Description

The SV5108/SV5108A are cost-effective, Standard Definition (SD) Video Drivers with enhanced video quality. With state-of-art low voltage and low power design, makes it ideal for low power CVBS-/SD- video system design. It features 5th-order filter and +6dB driver designed for replacing traditional 2nd~3th-order passive LC filtering solution that improves output video quality and reduces PCB space. The SV5108B supports driving single video cable or 150Ω load and two video cables or 75Ω loads.

The SV5108A can stay in power-down mode when the system is powered up. It will be activated while Video Jack plugging in, logic 'L' presenting at the SHDN pin, or enter power-down mode that saves power consumption when logic 'H' is presented at the SHDN pin.

The 8KV ESD protection design also helps to reduce ESD protection cost, but still provides robust ESD protection and reduces any potential system reliability and safety issues from ESD threats.

Block Diagram

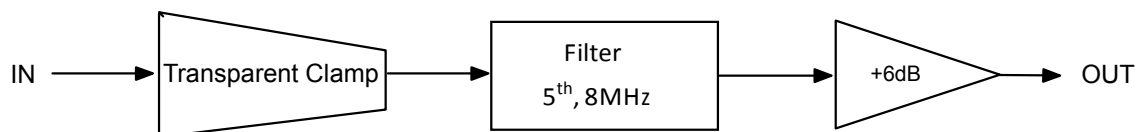

Ordering Information

Order Codes	Operation Range	Package	Packing
SV5108-05SC-TR3	-40°C, +85°C	SC70-5	Tape & Reel, 3000pcs
SV5108A-05SC-TR3	-40°C, +85°C	SC70-5	Tape & Reel, 3000pcs
SV5108-08SP-TR2	-40°C, +85°C	SOP-8	Tape & Reel, 2500pcs
SV5108A-08SP-TR2	-40°C, +85°C	SOP-8	Tape & Reel, 2500pcs

Pin Configuration (Top view)

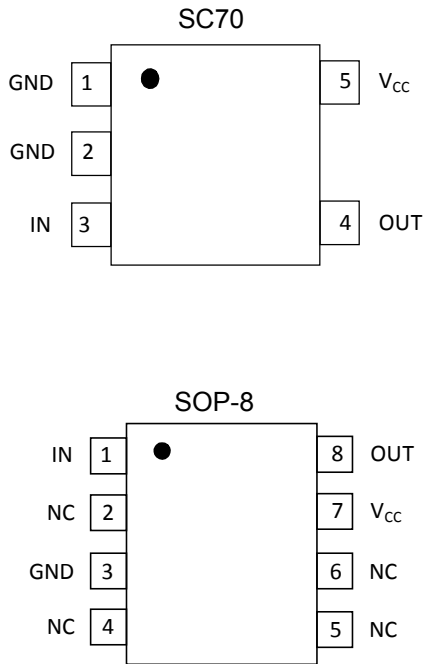

Pin Description

SOP-8 Pin	SC-7 Pin	NAME	FUNCTION
1	3	IN	Video input channel
2		NC	No connect
3	1, 2	GND	Ground
4		NC	No connect
5		NC	No connect
6		NC	No connect
7	5	V _{CC}	Power supply
8	4	OUT	Filter output channel

Absolute Maximum Ratings

Parameter	Value	Unit
V _{CC} to GND, Supply Voltage,	6	V
Input Voltage	GND - 0.3 to (V _{CC}) +0.3	V
Storage Temperature Range	-65 to +150	°C
Continuous current through V _{DD} or GND	100	mA
ESD Susceptibility: HBM	8000	V
ESD Susceptibility: MM	400	V

Stresses above those listed under Absolute Maximum Ratings may cause permanent damage to the device. This is a stress rating only; functional operation of the device at these or any other conditions above those indicated in the operational section of this specification is not implied. Exposure to absolute maximum rating conditions for extended periods may affect device reliability.

Caution

This integrated circuit can be damaged by ESD if you don't pay attention to ESD protection. SAVITECH recommends that all integrated circuits be handled with appropriate precautions. Failure to observe proper handling and installation procedures can cause damage. ESD damage can range from subtle performance degradation to complete device failure. Precision integrated circuits may be more susceptible to damage because very small parametric changes could cause the device not to meet its published specifications.

DC Electrical Characteristics

At $R_L = 150\Omega$ connected to GND, $V_{IN} = 1V_{pp}$, and $C_{IN} = 0.1\mu F$, all outputs AC coupled with $220\mu F$, referenced to 400kHz, unless otherwise noted.

PARAMETER	CONDITIONS	TEMP	MIN	TYP	MAX	UNITS
INPUT CHARACTERISTICS						
Output Level Shift Voltage (V_{OLS})	$V_{IN} = 0V$, no load	+25°C		386	572	mV
		-40°C to +85°C			670	
Input Voltage Clamp (V_{CLAMP})	$I_{IN} = -3.5mA$	+25°C	-220	-104		mV
		-40°C to +85°C	-300			
Clamp Charge Current	$V_{IN} = V_{CLAMP} - 100mV$	+25°C	-600	-470		uA
		-40°C to +85°C	-780			
Voltage Gain (A_v)	$R_L = 150\Omega$	+25°C	5.7	6	6.4	dB
		-40°C to +85°C	5.4		6.6	
OUTPUT CHARACTERISTICS						
Output Voltage High Swing	$V_{IN} = 3V$, $R_L = 150\Omega$ to GND	+25°C	4.3	4.74		V
		-40°C to +85°C	4.2			
POWER SUPPLY						
Operating Voltage Range		+25°C	2.7		5.5	V
Power Supply Rejection Ratio (PSRR)	$V_{CC} = 3.5V$ to $5.0V$	+25°C		62		dB
Quiescent Current (I_Q)	$V_{IN} = 0V$	+25°C		6		mA

Specifications are subject to change without notice.

Electrical characteristics: Standard-Definition Filter Driver

$V_{CC} = +4.2V$, $GND = 0V$, $T_A = -40^\circ C$ to $+85^\circ C$. $R_L = 150\Omega$ connected to GND, $V_{IN} = 1V_{pp}$, and $C_{IN} = 0.1\mu F$, all outputs AC coupled with $220\mu F$, referenced to 400kHz. Typical values are tested at $V_{CC} = +4.2V$, $T_A = +25^\circ C$ unless otherwise noted.

PARAMETER	CONDITIONS	TEMP	MIN	TYP	MAX	UNITS
AC PERFORMANCE						
-3dB Bandwidth	$R_L = 150\Omega$	+25°C		8		MHz
Filter Response (Normalized Gain)	$f_{IN} = 27MHz$	+25°C		-30		dB
Slew Rate	2V Output Step, 80% to 20%	+25°C		35		V/√s
Differential Gain (DG)	PAL DC coupled	+25°C		0.06		%
Differential Gain (DG) Differential Phase (DP)	PAL AC coupled	+25°C		0.09		%
	PAL DC coupled	+25°C		0.09		°C
Differential Phase (DP) Group Delay Variation (D/DT)	PAL AC coupled	+25°C		0.14		°C
	Difference between 400kHz and 6.5MHz	+25°C		3.5		ns
Crosstalk (channel - to - channel)	$f = 1MHz$	+25°C		-45		dB
Fall Time	2V Output Step, 80% to 20%	+25°C		26		ns
Rise Time	2V Output Step, 80% to 20%	+25°C		20		ns

Specifications are subject to change without notice.

Typical Performance Characteristics

At VCC= 5V, TA = +25°C, RL = 150Ω, all outputs AC coupled with 220uF, unless otherwise noted.

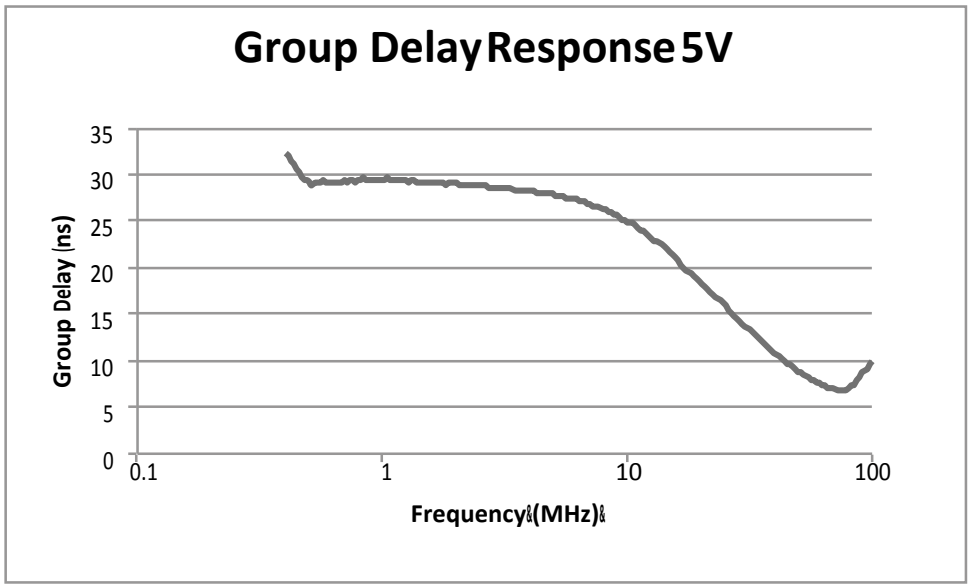
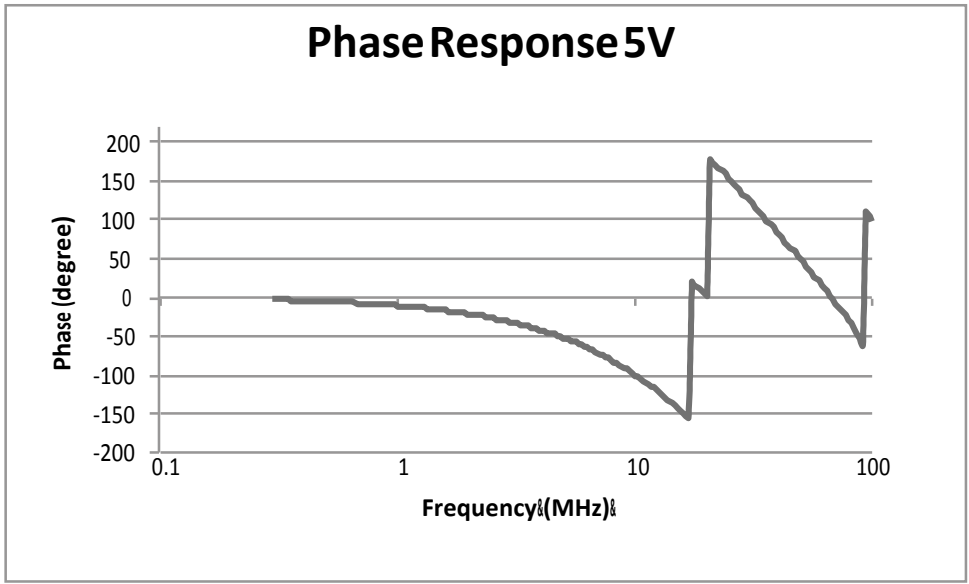
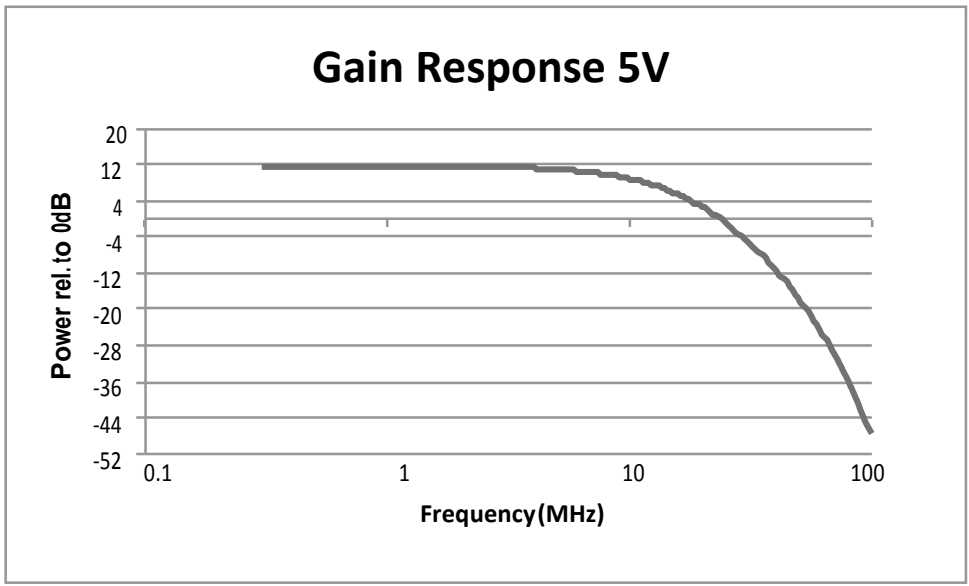

Typical Performance Characteristics

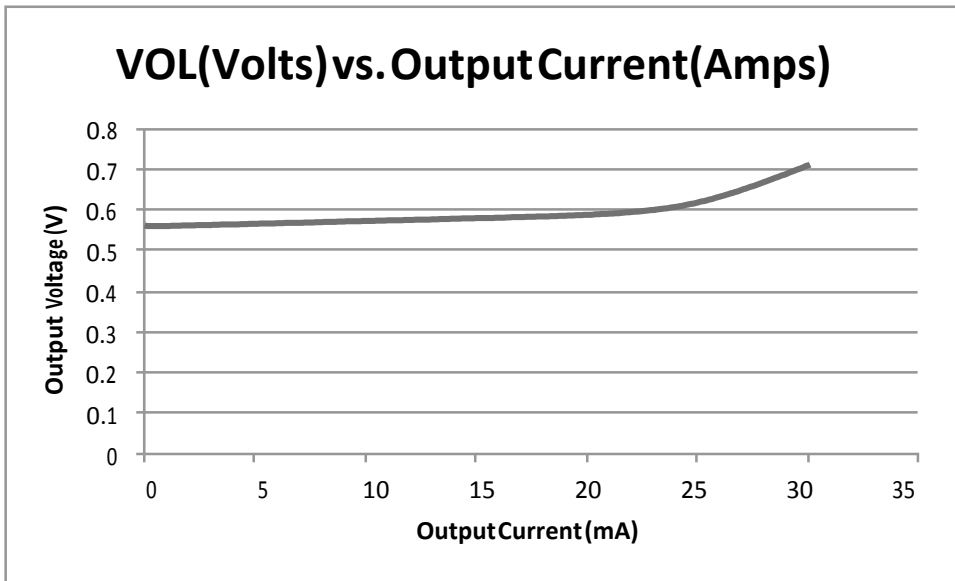
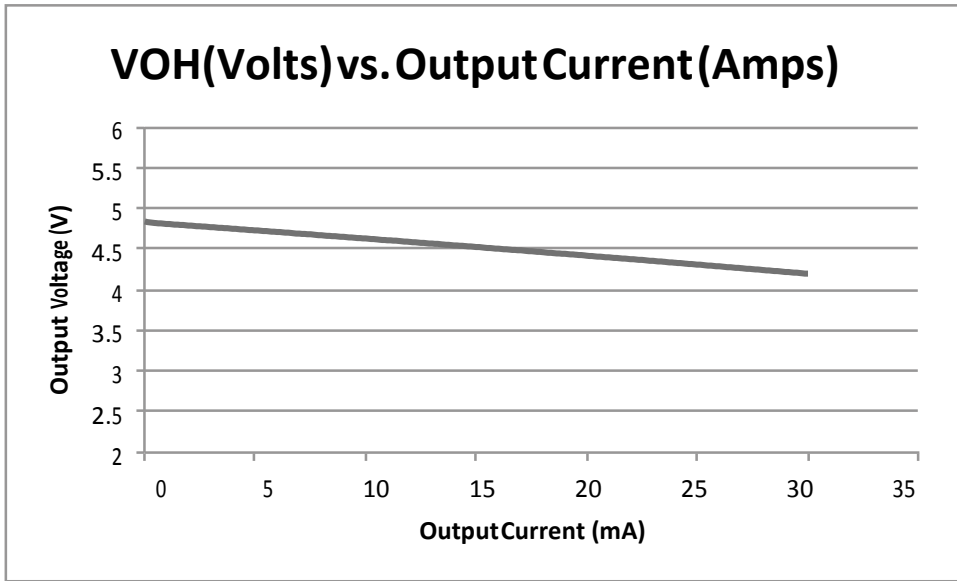

SC70-5 MECHANICAL DATA

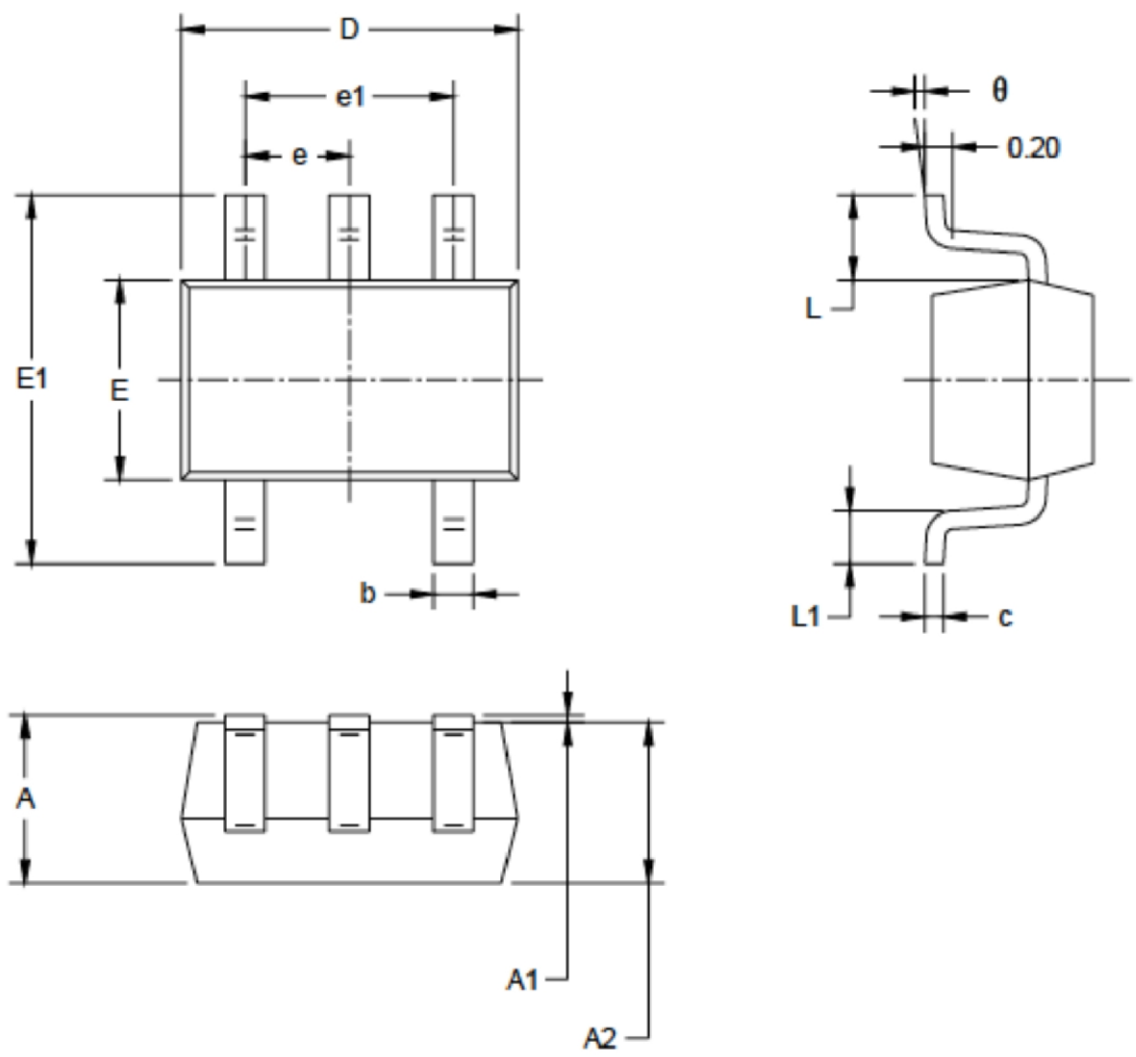

Symbol	Dimensions In Millimeters		Dimensions In Inches	
	MIN	MAX	MIN	MAX
A	0.900	1.100	0.035	0.043
A1	0.000	0.100	0.000	0.004
A2	0.900	1.000	0.035	0.039
b	0.150	0.350	0.006	0.014
c	0.080	0.150	0.003	0.006
D	2.000	2.200	0.079	0.087
E	1.150	1.350	0.045	0.053
E1	2.150	2.450	0.085	0.096
e	0.65 TYP		0.026 TYP	
e1	1.300 BSC		0.051 BSC	
L	0.525 REF		0.021 REF	
L1	0.260	0.460	0.010	0.018
θ	0°	8°	0°	8°

SOP-8 MECHANICAL DATA

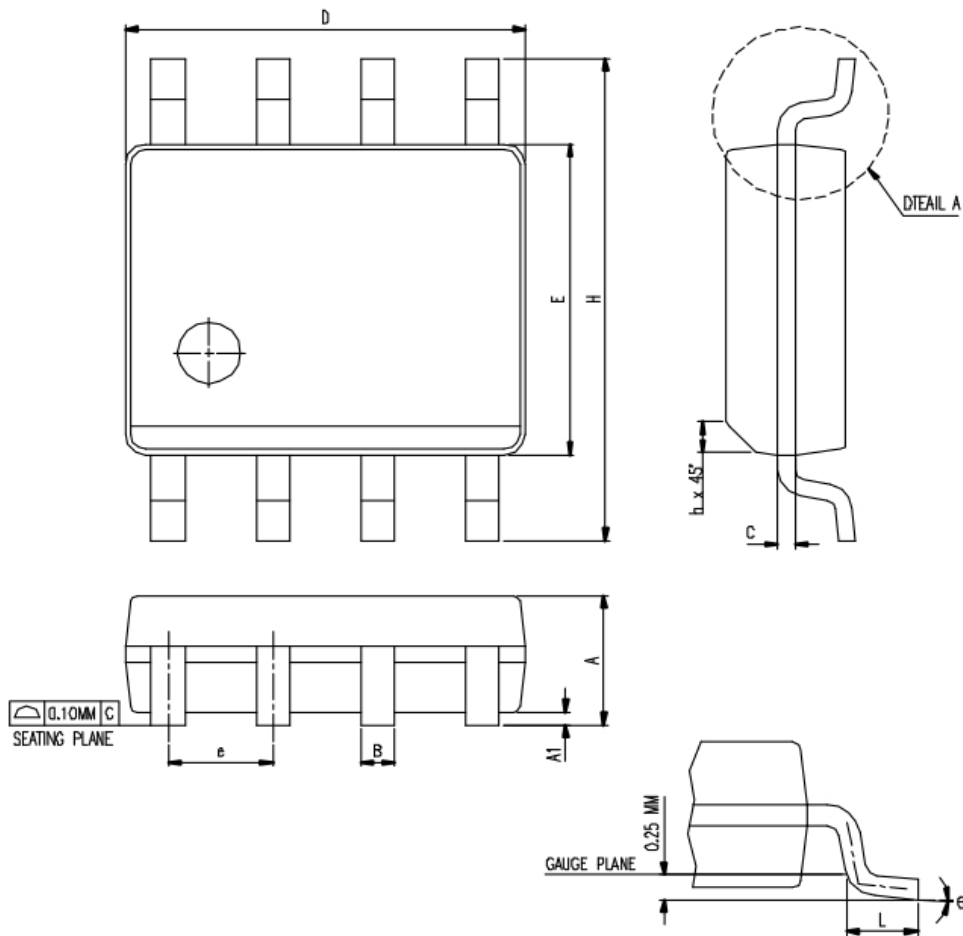

Symbol	Dimension in MM		Dimension in Inch	
	Min.	Max.	Min.	Max.
A	1.35	1.75	0.0532	0.0688
A1	0.10	0.25	0.004	0.0098
B	0.33	0.51	0.013	0.02
C	0.19	0.25	0.0075	0.0098
e	1.27BSC		0.050 BSC	
D	4.80	5.00	0.1890	0.1968
H	5.80	6.20	0.2284	0.2440
E	3.80	4.00	0.1497	0.1574
L	0.40	1.27	0.016	0.050
h	0.25	0.50	0.0099	0.0196
Θ	0*	8*	0*	8*
JEDEC	MS-012 (AA)			

DTEAIL A

***Notes:**

Dimension "D" does not include mold flash, Protrusions or gate burrs.
 Mold flash, protrusions and gate burrs shall not exceed 0.15 MM (0.006 Inch) per side.

Information furnished is believed to be accurate and reliable. However, SAVITECH assumes no responsibility for the consequences of use of such information nor for any infringement of patents or other rights of third parties that may result from its use. No license is granted by implication or otherwise under any patent or patent rights of SAVITECH. Specifications mentioned in this publication are subject to change without notice. This publication supersedes and replaces all information previously supplied. SAVITECH products are not authorized for use as critical components in life support devices or systems without express written approval of SAVITECH.

The SAVITECH logo is a registered trademark of Savitech Corporation.

All other names are the property of their respective owners

© 2011 Savitech Corporation - All Rights Reserved